



# SERVICE TECH, INC.

Activated Carbon Engineering, Sales and Service

## LIQUIDCLEAN - HP 5000 5000 POUND HIGH PRESSURE ACTIVATED CARBON ADSORBER STANDARD FEATURES

- \* 5000#S of virgin activated carbon, coal base, 8x30 mesh.
- \* Standard 3"FNPT couplings for easy installation.
- \* Heavy duty, corrosion resistant *Polyglass*<sup>®</sup> composite poly vessel
- \* Hub & lateral internal distribution and collection assemblies designed to maximize flow & carbon utilization.
- \* High pressure vessel rated to 150 psig operation @ 150°F.

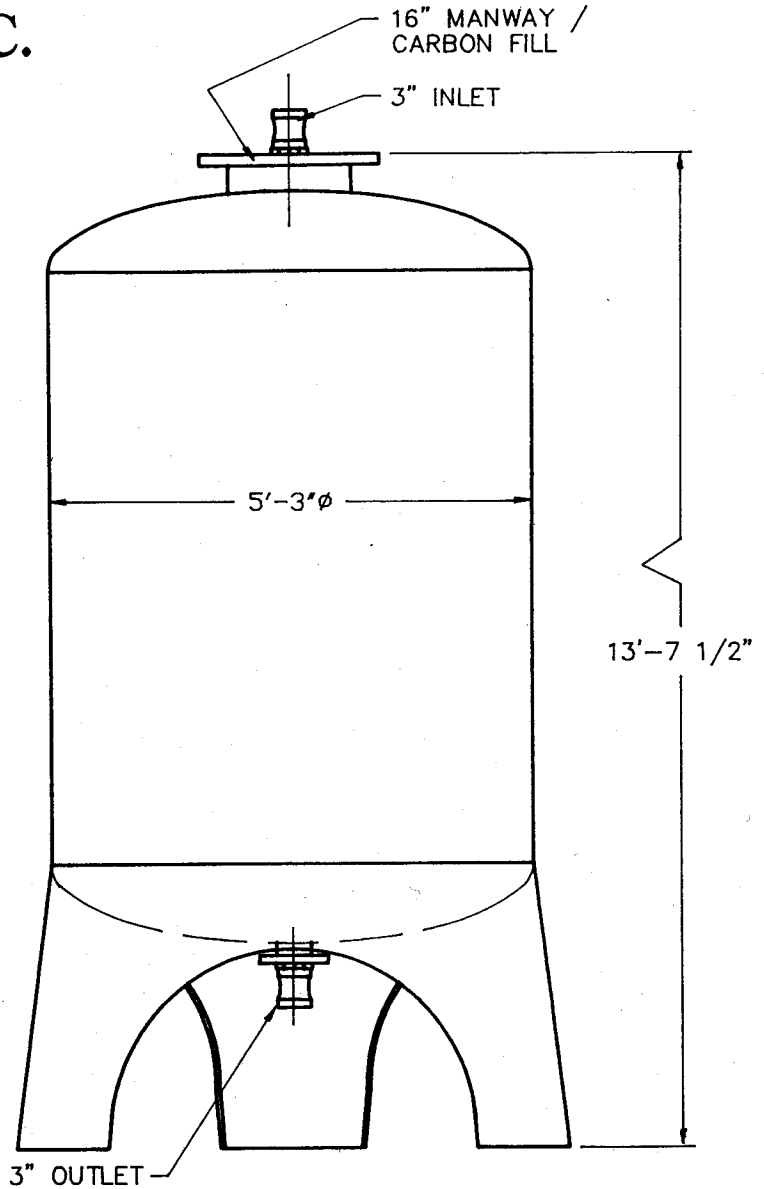

## SPECIFICATIONS

Max Suggested Flow	— 200 GPM
Typical Flows	— 40 to 150 GPM
Inlet	— 3" fnpt
Outlet	— 3" fnpt
Max Operating Temperature	— 150°F
Max Operating Pressure	— 150 psi max. operating pressure

\* Based on (2) units operating in series and may not be effective in all applications.

SERVICE TECH 5000 HP  
PRESSURE DROP CURVE

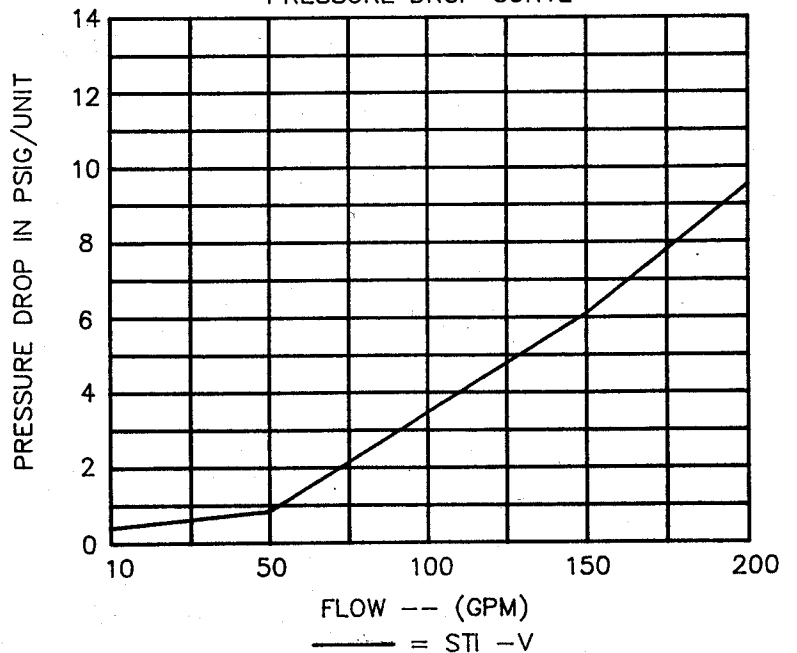

(508) 673-9784 • Toll Free (800) 368-0043 • Fax (508) 673-6151

• Mailing: P.O. Box 8093, Cranston, RI 02920 • Sales & Distribution: 1658 G.A.R. Highway, Swansea, MA 02777 • Warehouse & Manufacturing: 1980 Fall River Avenue, Seekonk, MA 02771